

PARKSIDE



PTBM 350-13

CE 2002

Ⓞ Operating
and safety instructions



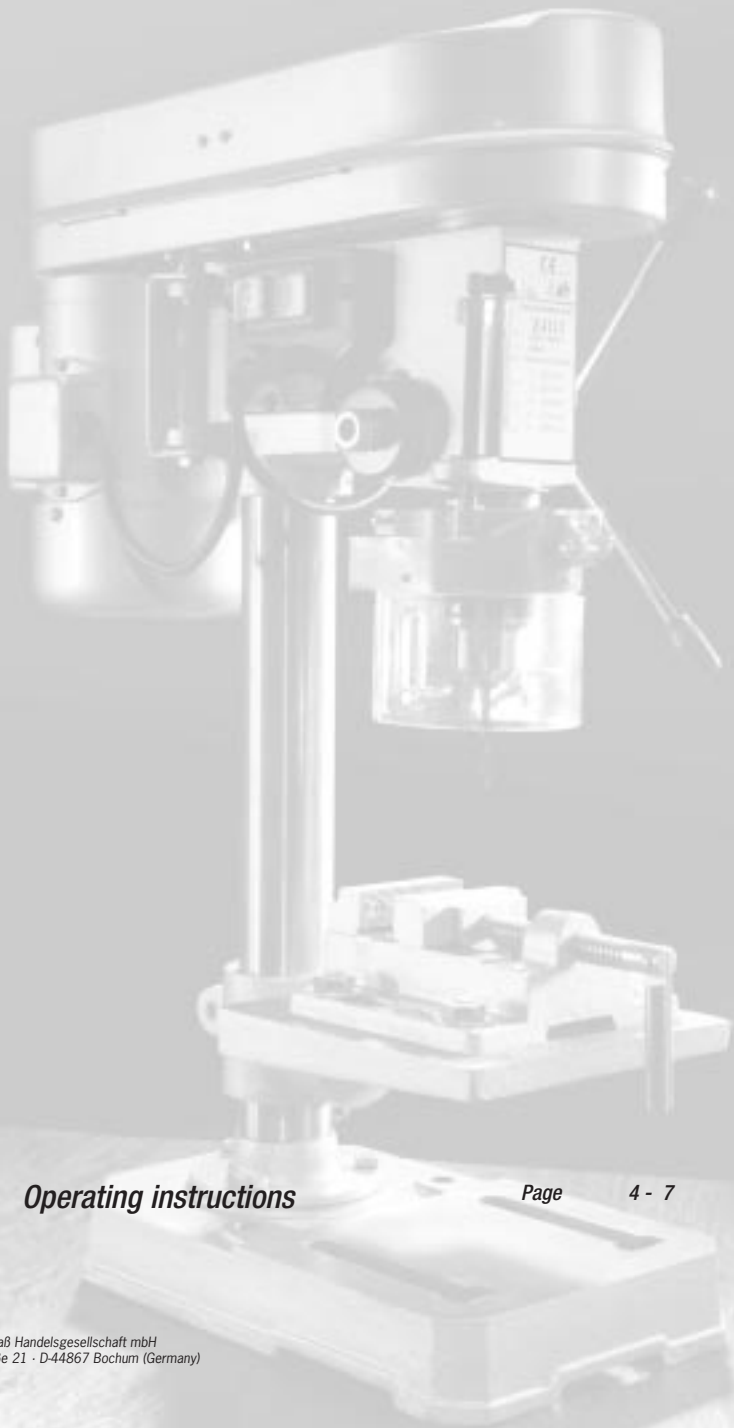

Operating instructions

Page

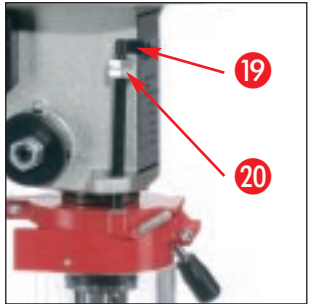
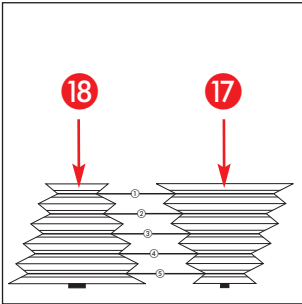
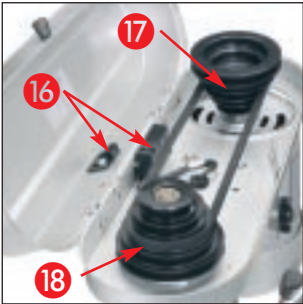
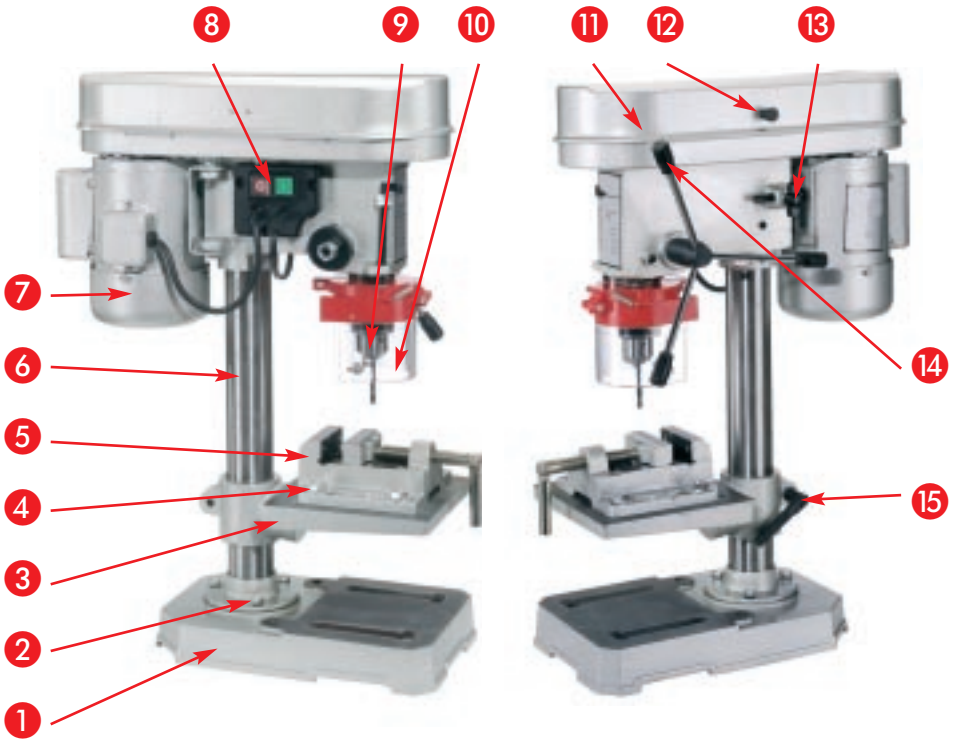

4 - 7



PARKSIDE

PARKSIDE

BENCH DRILL PTBM 350-13 For drilling in wood, plastic and metal





Please read carefully through the following information concerning safety and proper use. Before reading, fold out the page with the illustrations and make yourself familiar with all the functions of the equipment. Please read the operating instructions  below and the accompanying safety advice  carefully. Use the equipment only as described and for the indicated purposes. By doing this you will be able to work in complete safety and produce better results.

Be careful to keep these advice notes and if necessary pass them on to a third party.

PROPER USE

The bench drill is intended for drilling in wood, plastic and metal using normal drill bits up to a maximum diameter (\varnothing) of 13 mm. Any other use of or modification to the machine shall be considered as improper use and could give rise to serious danger.

SPECIFIC SAFETY ADVICE

- △ In addition, you must also read the advice in the accompanying booklet called "Safety advice" before using the equipment for the first time.
- △ When you are using the bench drill always wear ear protectors and protective glasses. We recommend that you wear robust anti-slip footwear, a working apron or close-fitting clothing, If you have long hair you should wear some sort of hair protection (such as a hair net, cap or headscarf) to ensure that your hair does not become trapped in moving machine parts or twisted about the drill bit or chuck. Do not wear gloves when drilling.    
- △ Do not remove any mechanical or electrical safety devices.
- △ Always check that all safety devices are attached and properly fixed in place.
- △ Always check that the workpiece is firmly and securely clamped in place.
- △ Never drill a workpiece whilst holding it in your hands.
- △ Check that the chuck is properly attached.
- △ Never clean or lubricate the bench drill when it is in motion.
- △ Before adjusting, maintaining or repairing the drill, always remove the plug from the mains socket.
- △ Use a hand brush to remove drilling swarf.
- △ Ensure that you work safely by firmly fixing down the machine on to a working surface.
- △ Always keep the drive/ belt cover closed to keep hands and fingers out.
- △ Always use the key to open or close the drill chuck.

FEATURES OF THE PTBM 350-13

- ① Base plate
- ② 3 column/base fixing screws
- ③ Drilling table
- ④ 4 drill vice screws
- ⑤ Drill vice
- ⑥ Column
- ⑦ Motor unit
- ⑧ On/off switch

- 9 Chuck
- 10 Drill chuck guard
- 11 Drive/belt cover
- 12 Drive/belt cover handle *
- 13 Adjustment screw
- 14 Handle/spindle control
- 15 Table clamp screw
- 16 Contacts *
- 17 Drive (motor side) } Gears
- 18 Drive (spindle side) }
- 19 Depth stop with scale
- 20 Adjustment nut

* = form and type may differ from that shown in the illustrations

TECHNICAL INFORMATION

Mains connection:	230 V ~ 50 Hz	<u>Spindle speed:</u>	1. Setting: 2600 rpm
Current:	1.9 A		2. Setting: 1750 rpm
Nominal power:	350 W		3. Setting: 1250 rpm
Nom. speed, no load:	n ₀ 1400 rpm (motor)		4. Setting: 900 rpm
Power factor:	0.8		5. Setting: 600 rpm
Duty cycle:	60 %		
Drilling capacity:	13 mm		
Spindle travel:	50 mm		
Sound pressure level:	75 dB (A)		
Vibration:	2.5 m/s ² (vibration)		
Weight:	approx. 19.5 kg		

We reserve the right to make technical modifications and changes without notice to the appearance of the equipment in the course of further development.

ASSEMBLY

The bench drill is supplied ready to assemble. Remove the parts carefully from the packaging and assemble the bench drill in the following manner:

1. Insert the column 6 into the base plate 1 and tighten the screws (3 column/base fixing screws 2).
2. Place the drilling table 3 on to the column 6 and fix it in position using the table clamp screw 5.
3. Fix the drill vice 4 (4 drill vice screws 4) on to the drilling table 3.
4. Place the pre-assembled motor unit 7 on to the column. The motor unit is attached by two hexagonal socket screws on the right hand side.
5. Attach the three armed handle/spindle control 14 in the rise and fall shaft.
6. Attach the chuck 9 firmly to the drill spindle cone.

Attention: Clean the drill spindle cone thoroughly to remove all traces of grease.

SETTING UP THE MACHINE

Set the bench drill down on a firm surface and level it using a spirit level. We recommend that the machine is bolted down on to the supporting surface. Please ensure that the base plate 1 is not subject to any additional forces as a result of being bolted down.

INSTALLATION AND FIRST USE

Check that the supply type, voltage and fuses comply with those specified for the machine.

First clean any anti-rust coating carefully from the parts. Then oil the column.

SWITCHING THE MACHINE ON AND OFF

Insert the plug into the mains socket and switch on the machine using the "I" button at the on/off switch ①. To switch off use the "O" button.

CHECKING AND TENSIONING THE V-BELT

Open the drive/belt cover ① and check the V-belt tension. If it is correctly adjusted the V-belt should be able to be moved approximately 1 cm in the middle between the two drive wheels. Loosen the adjustment screw ② and press the motor unit ③ backwards before retightening the adjustment screw ④.

SETTING THE SPEED

The bench drill has 5 different speeds. The speed is set by simply repositioning the V-belt. To do this open the drive/belt cover ①, loosen the adjustment screw ② and place the V-belt on the relevant pair of drive wheels.

Note: The top pair give the highest speed; the bottom pair the lowest (① = 2600, ② = 1750, ③ = 1250, ④ = 900, ⑤ = 600, see figure on page 3).

Then tension the V-belt as described in the section on "Tensioning the V-belt".

Note: Inside the drive/belt cover ① there is a contact which must come together with an opposing contact (see ⑥) on the drive/belt casing base when the drive cover is closed. The motor can only be restarted if the drive/belt cover ① is properly closed.

SETTING THE DRILLING TABLE

The drilling table ③ can be adjusted by loosening the table clamp screw ④.

Set the table so that there is an adequate distance between the workpiece top surface and the drill bit point.

The table can be swung to the side, e.g. when you wish to work on a tall workpiece that can be attached directly to the base plate.

DEPTH STOP / DRILLING TO AN EXACT DEPTH

The depth stop with its scale ② allows you to drill to an exact depth.

First of all press lightly down on to the top of the workpiece surface using the handle ③ and set the drilling depth using the adjustment nut ④ on the scale.

Note: Make sure that you take into account the length of the drill bit point (normally approx. 5 mm) when determining the appropriate setting for the cylindrical part of a drilled hole.

INCLINED DRILLING

The drilling table ③ can be rotated to drill angle holes or to accommodate workpieces with inclined ends. Release the hexagonal socket screws on the drilling table swivel joint. Place the table at the required slope and retighten the hexagonal socket screws.

ADVICE ON DRILLING WORKPIECES

The following points should be observed at all times:

- always use sharp tools
- cool the drill bit with a suitable liquid
- use a special drill bit for drilling into stainless steel
- for very hard materials use a higher pressure at lower speed setting
- for soft materials apply light pressure at a higher speed
- Attention: too high a pressure overloads the motor and reduces the drilling speed
- small drills require a high drill speed
- larger drills require a lower drill speed

The following table gives further helpful advice:

- the correct speed is different for each material
- the cutting speed is dependent on the diameter of the drill and the rotation speed
- the table gives the approximate rotation speed
- please note that an average speed has been calculated for the listed materials and the rotation speeds have been rounded
- in some cases the calculated cutting speeds (CS) cannot be selected in practice - use the nearest available value

Material	CS	Drill size									
		2	3	4	5	6	7	8	9	10	13
Wood, soft	300 rpm	max.	max.	max.	max.	max.	max.	max.	max.	max.	max.
Wood, medium	180 rpm	max.	max.	max.	max.	max.	max.	max.	max.	max.	max.
Aluminium "hard"	120 rpm	max.	max.	max.	max.	max.	max.	max.	max.	3800	2950
Wood "hard", copper	60 rpm	max.	max.	max.	3800	3200	2700	2400	2100	1900	1500
Steel or sheet metal	35 rpm	max.	3700	2800	2250	1850	1600	1400	1250	1100	850
Aluminium "soft"	30 rpm	max.	3200	2400	1900	1600	1350	1200	1050	950	700
Structural steel	25 rpm	4000	2650	2000	1600	1300	1150	1000	900	800	600
Alloy steel	10 rpm	1600	1100	800	650	500	450	400	350	300	250
Stainless steel (VA steel)	10 rpm	1250	850	650	500	400	350	300	280	250	200

DECLARATION OF CONFORMITY

We, Kompernaß Handelsgesellschaft mbH, Burgstr. 21, D-44867 Bochum, Germany, declare that this product complies with the following EU directives:

Machinery Directive (98/37 EC), Low Voltage Directive (73/23 EEC, 93/68 EEC), Electromagnetic Compatibility (89/336 EEC, 93/68 EEC) in accordance with the applicable standards, and confirm this with the CE mark.

Type/machine description: PARKSIDE BENCH DRILL PTBM 350-13

Bochum, 31.08.02



Hans Kompernaß
- Managing Director -

PARKSIDE

WARRANTY

This piece of equipment is covered by a **36-month warranty as of the date of purchase**. The equipment was produced with the greatest of care and underwent thorough testing before delivery. In the unlikely event of detecting a functional defect, please return the equipment in its original packaging with the proof of purchase (if available) to the closest service address.

Damage caused due to improper handling as well as regular wear of the parts are not covered by this warranty.

Beaver Electronic Services · The Lodge, Premier Business Park

Long Street, Walsall · West Midlands, WS2 9DY

Tel.: 0 19 22/72 55 54 · Fax: 0 19 22/72 54 17

WARRANTY

This piece of equipment is covered by a **36-month warranty as of the date of purchase**. The equipment was produced with the greatest of care and underwent thorough testing before delivery. In the unlikely event of detecting a functional defect, please return the equipment in its original packaging with the proof of purchase (if available) to the closest service address.

Damage caused due to improper handling as well as regular wear of the parts are not covered by this warranty.

Irish Web Specialists

1 Verbena Avenue · Dublin 13

Tel.: 01/8 32 04 92 · Fax: 01/8 39 68 29

PARKSIDE



CE
Z4115
1000W
110V
1100rpm
10mm
10mm
10mm
10mm
10mm
10mm